

LINEAR VOLTAGE REGULATOR THREE TERMINAL-POSITIVE-ADJUSTABLE 7.5 Amp, Low Dropout Voltage LCC-3P (SMD Hermetic Package)

Features:

- **Three-Terminal Adjustable**
- **Operates Down to 1V Dropout**
- **Guaranteed Dropout Voltage at Multiple Current Levels**
- **On-Chip Thermal Limiting**
- **Line Regulation: 0.035%**
- **Load Regulation: 0.20%**
- **Fixed Versions Available**
- **Electrically Equivalent to LT®1083**

Description: This positive adjustable regulator is designed to provide 7.5A with high efficiency using simple 3-terminal configurations. All internal circuitry is designed to operate down to 1V input-to-output differential and the dropout voltage is fully specified as a function of load current. Dropout is guaranteed at a maximum of 1.5V at maximum output current, decreasing at lower load currents. Available in fixed voltages.

Current limit is trimmed to ensure specified output current and controlled short-circuit current. On-chip thermal limiting provides protection against any combination of overload that would create excessive junction temperatures.

Applications:

- **High Efficiency Linear Regulators**
- **Post Regulator for Switching Supplies**
- **Constant Current Regulators**

ELECTRICAL CHARACTERISTICS $-55^{\circ}\text{C} \leq T_A \leq 125^{\circ}\text{C}$ (UNLESS OTHERWISE SPECIFIED)

PARAMETER	SYMBOL	Test Conditions	Min	TYP	Max.	Units
Input Voltage	V _{in}			-	35	V
Reference Voltage	V _{ref}	1.5V < (V _{in} -V _{out}) ≤ 25V, I _{out} ≤ 7.5A	1.225	1.250	1.270	V
Line Regulation Note(1,2)	ΔV _{out} /ΔV _{in}	1.50V < V _{in} < 15V, I _{out} = 10mA		0.035	0.20	%
Line Regulation Note(1,2)	ΔV _{out} /ΔV _{in}	(V _{in} -V _{out}) = 15V to 30V 10mA < I _{out} < I _{full load}		0.60	1.00	%
Load Regulation Note(1,2,3)	ΔV _{out} /ΔI _{out}	(V _{in} -V _{out}) = 3V 10mA < I _{out} < I _{full load}		0.50	1.00	%
Dropout Voltage	V _{D0}	ΔV _{ref} = 1%, I _{out} = 7.5A		1.30	1.50	V
Current Limit	I _{LIM}	(V _{in} -V _{out}) = 5V	8.00	9.50	-	A
Current Limit	I _{LIM}	(V _{in} -V _{out}) = 25V	0.40	1.00	-	A
Adjust Pin	I _{adj}	Typical value is at T _j = 25°C		55	120	μA
Adjust Pin Current Change	ΔI _{adj}	1.5V < (V _{in} -V _{out}) < 25V, 10mA < I _{out} < I _{full load}		0.2	5	μA
Minimum Load Current	I _{MIN}	(V _{in} -V _{out}) = 25V		5	10	mA
Quiescent Current	I _q	V _{in} = 5.0V		8	13	mA
Ripple Rejection	ΔV _{in} /ΔV _{out}	f = 120Hz, C _{adj} = 25μF, C _{out} = 25μF(T _{ant.}), (V _{in} -V _{out}) = 3V, I _{out} = 7.5.0A	60	72	-	dB
Thermal Regulation		T _A = °C, 30ms Pulse		0.004	0.02	%/W
Temperature Stability	ΔV _{out} /ΔT	-55°C < T _j < +125°C		0.50		%
Long Term Stability	ΔV _{out} /ΔT	T _A = +125°C, t = 1000hrs		0.30	1.0	%
RMS Output Noise	(% of V _{out})	T _A = 25°C, 10Hz < f < 10kHz		0.003	-	%
Thermal Resistance (J-C)	T _{jc}	Surface mount LCC-3P package		-	1.43	°C/W

Notes:

- 1) See thermal regulation specification for changes in output voltage due to heating effects. Load and line regulation are measured at a constant junction temperature by low duty cycle pulse testing.
- 2) Line and load regulation is guaranteed up to the maximum power dissipation in the package. Input/output differential and the output current determine power dissipation. Guaranteed maximum output power will not be available over the full / input/output voltage range.
- 3) I_{Full} Load is defined as the maximum value of output load current as a function of the input-to-output voltage. I_{Full} Load is equal to 7.5 Amps.

TECHNICAL DATA
DATA SHEET 987, REV. -

5V, 7.5A Regulator

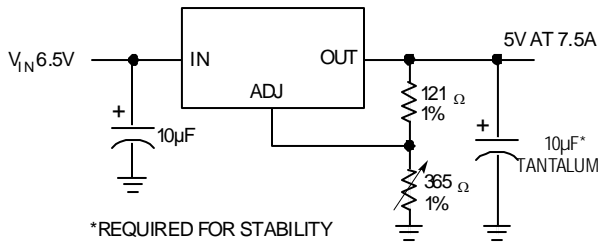

Dropout Voltage vs Output Current

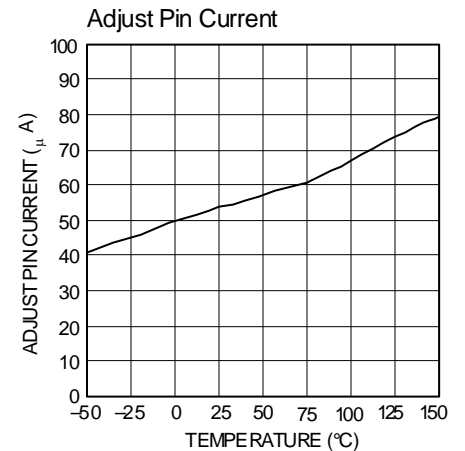
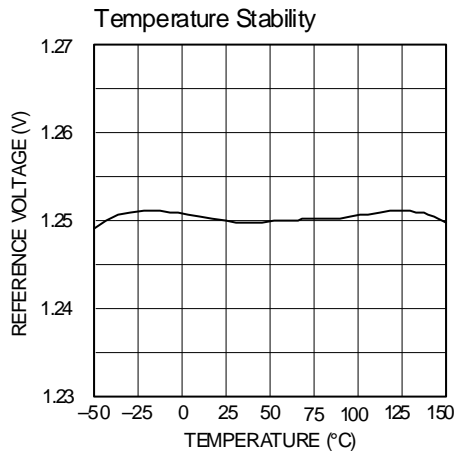
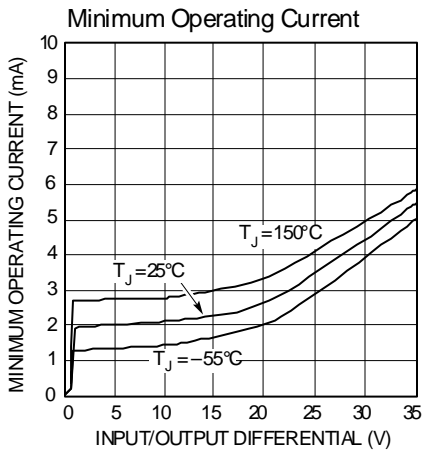
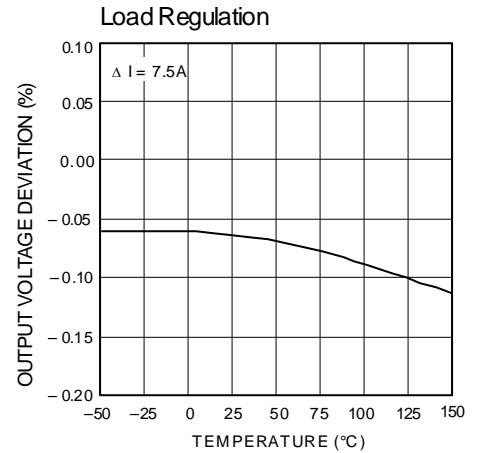
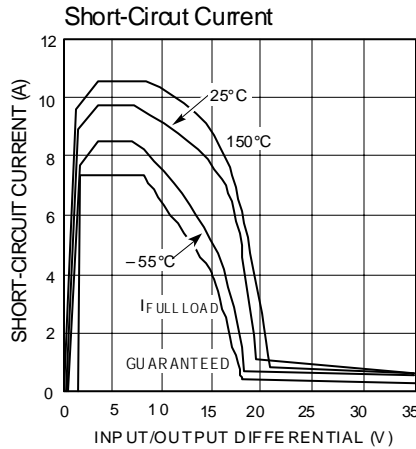
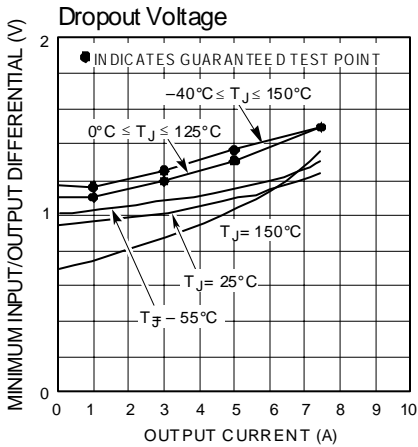
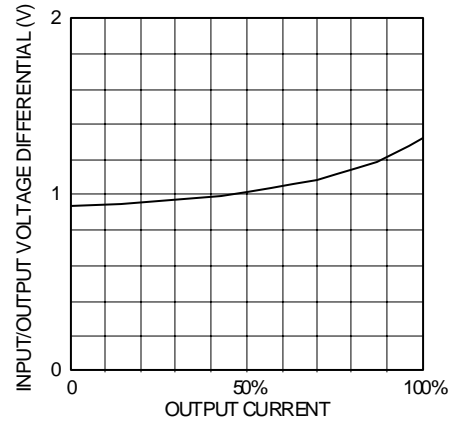

TECHNICAL DATA
DATA SHEET 987, REV. -

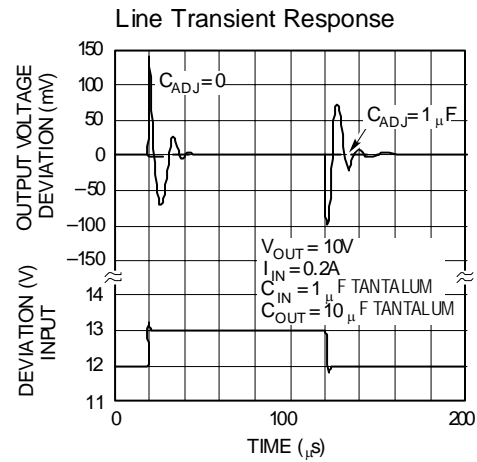
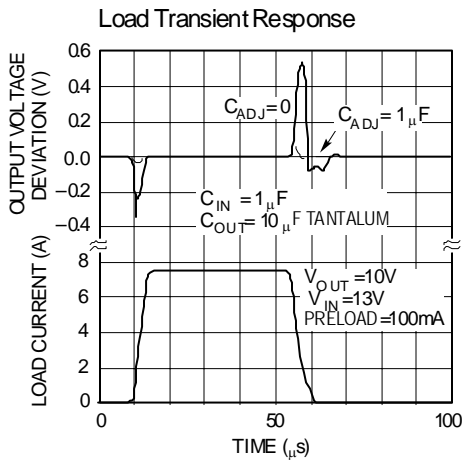

Adjustable Regulator Configuration or Changing Voltage of Fixed Regulator

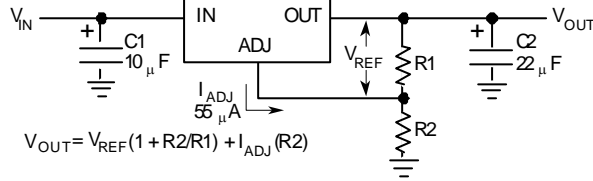

Optional Configuration to Reduce Low Side Parasitic Resistance Effects

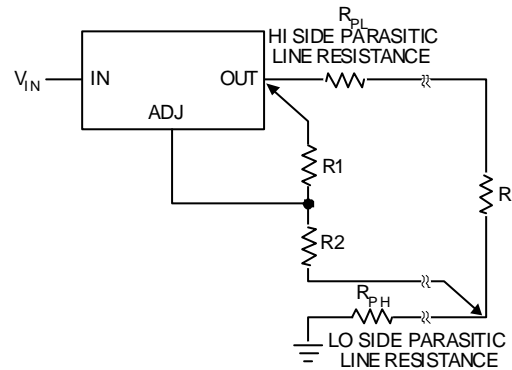

TECHNICAL DATA
DATA SHEET 987, REV. -

Block Diagram

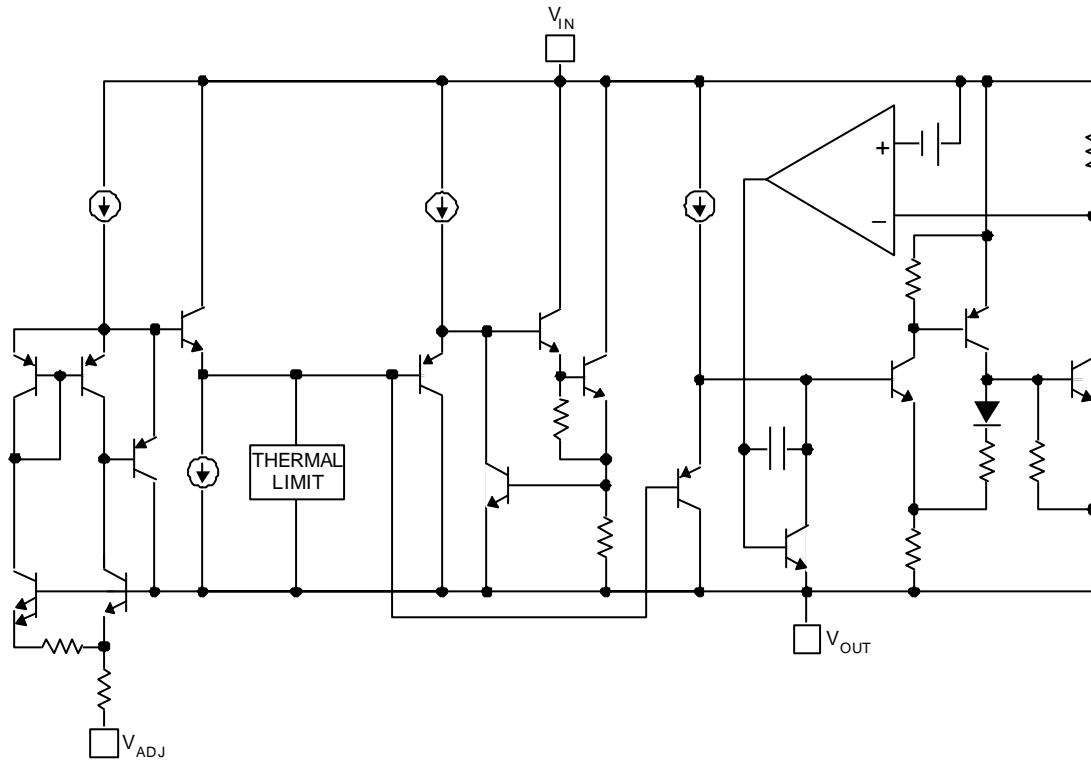

MECHANICAL DIMENSIONS: in Inches / mm

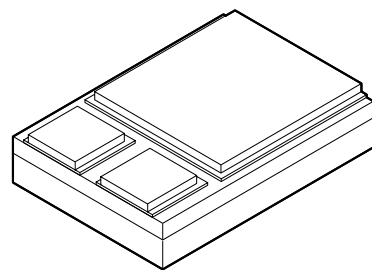
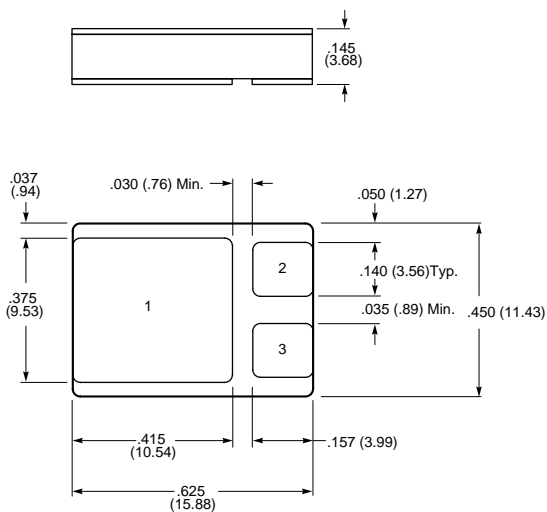

LCC-3P

Pad 1 = V_{out} , Pad 2 = Adjust, Pad 3 = V_{in} (Contact factory for other configurations)

TECHNICAL DATA
DATA SHEET 987, REV. -**DISCLAIMER:**

1- The information given herein, including the specifications and dimensions, is subject to change without prior notice to improve product characteristics. Before ordering, purchasers are advised to contact the Sensitron Semiconductor sales department for the latest version of the datasheet(s).

2- In cases where extremely high reliability is required (such as use in nuclear power control, aerospace and aviation, traffic equipment, medical equipment, and safety equipment), safety should be ensured by using semiconductor devices that feature assured safety or by means of users' fail-safe precautions or other arrangement.

3- In no event shall Sensitron Semiconductor be liable for any damages that may result from an accident or any other cause during operation of the user's units according to the datasheet(s). Sensitron Semiconductor assumes no responsibility for any intellectual property claims or any other problems that may result from applications of information, products or circuits described in the datasheets.

4- In no event shall Sensitron Semiconductor be liable for any failure in a semiconductor device or any secondary damage resulting from use at a value exceeding the absolute maximum rating.

5- No license is granted by the datasheet(s) under any patents or other rights of any third party or Sensitron Semiconductor.

6- The datasheet(s) may not be reproduced or duplicated, in any form, in whole or part, without the expressed written permission of Sensitron Semiconductor.

7- The products (technologies) described in the datasheet(s) are not to be provided to any party whose purpose in their application will hinder maintenance of international peace and safety nor are they to be applied to that purpose by their direct purchasers or any third party. When exporting these products (technologies), the necessary procedures are to be taken in accordance with related laws and regulations.