

Sensitron MOS Gated Thyristors

MOS Gated Thyristors (MGTs) blend the high-current, high-power capability of a traditional thyristor with the efficient, low-energy gate control of a MOSFET. This hybrid design provides full controllability using minimal gate drive current, enabling both turn-on and turn-off through simple voltage signals. MGTs deliver excellent power handling, low on-state conduction losses, and reliable performance in demanding high-voltage, high-current applications—making them an ideal choice for next-generation power switching solutions.

Key Features of MOS Gated Thyristors (MGTs)

- Low gate drive requirements**

The MOS gate structure demands minimal gate current, enabling simpler, lower-loss gate-drive circuitry.

- High power capability**

MGTs retain the high-voltage and high-current handling strengths of traditional thyristors, making them ideal for demanding high-power systems.

- High surge current tolerance**

Engineered to withstand extremely high current surges over short durations, providing robust performance in transient-heavy environments.

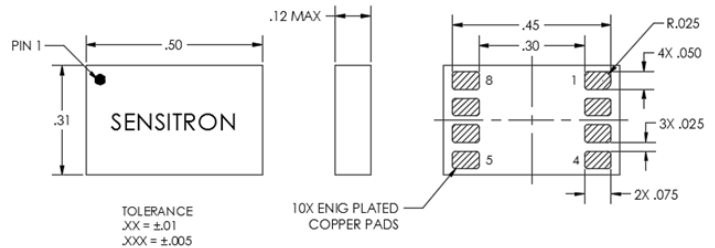
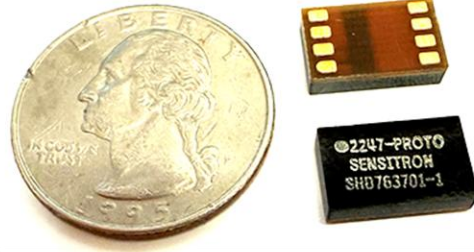

Features/Benefits:

- Circuit charges capacitors up to ~1200V
- High voltage holding while delivering rapid current dump
- Precision power control

Applications:

- Ideal for capacitive discharge and ignition circuits
- Triggers LEEFI (Low Energy Exploding Foil Initiators), e.g., Reynolds
- Solid state surge protection

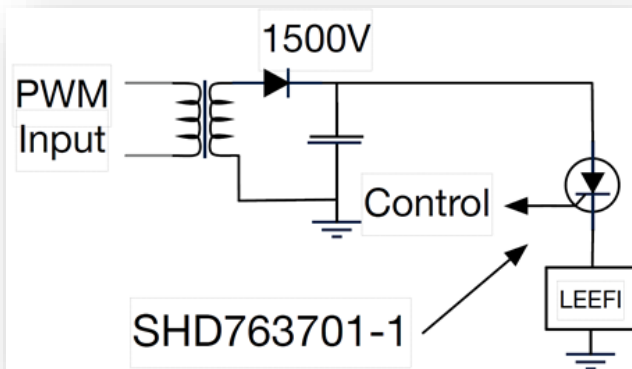

About Sensitron:

Sensitron has over 50 years of heritage as a leading manufacturer of high reliability power electronic component solutions for the Defense, Aerospace, Space, and Medical markets. Our products provide rugged, light-weight, and cost-effective solutions for switching power supplies, AC-DC rectification, primary & secondary power distribution, motion control, transient voltage spike protection, and custom applications. <http://www.sensitron.com>

MOS Gated Thyristors (MGTs)